

### KEY FEATURES

- 1,4" exit (36 mm) high frequency compression driver
- 2,5" (63,5 mm) edgewound aluminium ribbon voice coil
- Sensitivity 108 dB (1W / 1m)
- 160 W program power above 1 kHz
- PM-4 polymer diaphragm for natural sound reproduction
- Copper shorting cup
- Aluminium cover
- FEA optimized neodymium motor structure

### TECHNICAL SPECIFICATIONS

Throat diameter	36 mm	1,4 in
Rated impedance		8 $\Omega$
Minimum impedance	7,6 $\Omega$ @ 3,5 kHz	
D.C. resistance		5,3 $\Omega$
Power capacity*	80 W <sub>AES</sub> above 1 kHz	
Program power	160 W above 1 kHz	
Sensitivity**	108 dB 1W / 1m @ Z <sub>N</sub> coupled to TD-385	
Frequency range	0,6 - 17 kHz	
Recommended crossover	0,8 kHz or higher (12 dB/oct min.)	
Voice coil diameter	63,5 mm	2,5 in
Flux density		1,7 T
BI factor		10 N/A

### MOUNTING INFORMATION

Overall diameter	120 mm	4,72 in
Depth	49 mm	1,93 in
Mounting	Four M6 threaded holes, 90° apart on 101,6 mm (4") diameter circle	
Net weight	1,9 kg	4,19 lb
Shipping weight	2,1 kg	4,63 lb

#### Notes:

\* The power capacity is determined according to AES2-1984 (r2003) standard. Program power is defined as the transducer's ability to handle normal music program material.

\*\* Sensitivity was measured at 1m distance, on axis, with 1W input, averaged in the range 1 - 7 kHz.



### DIMENSION DRAWINGS

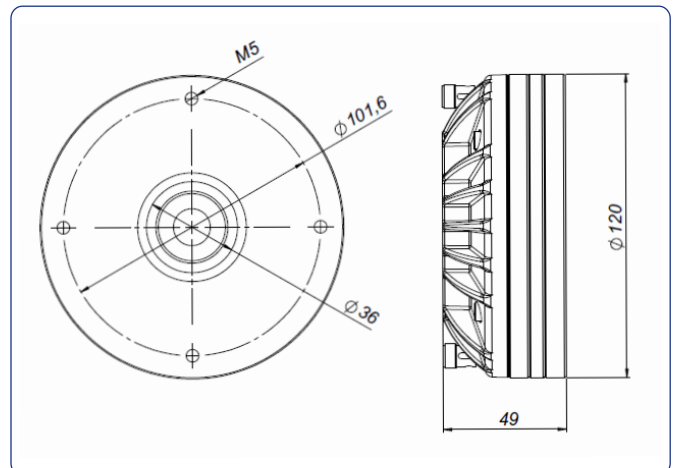

### FREE AIR IMPEDANCE CURVE

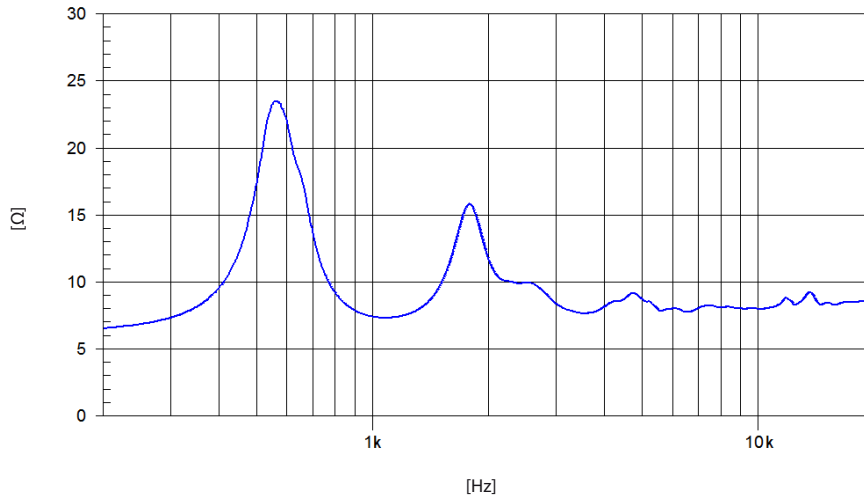

### FREQUENCY RESPONSE

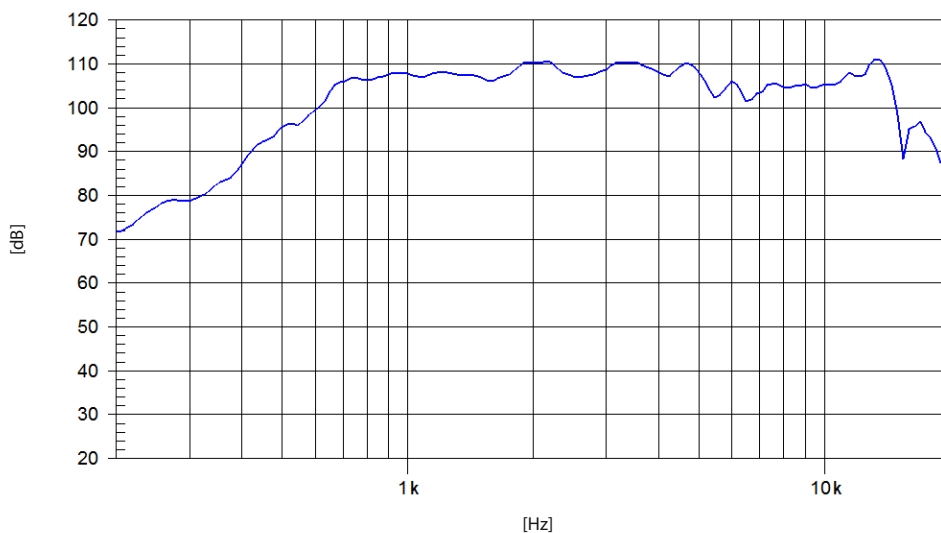

**Note:** On axis frequency response measured coupled to TD-385 horn in anechoic chamber, 1W @ 1m